

DEPARTMENT OF THE ARMY TECHNICAL MANUAL

TRANSPORTABILITY GUIDANCE
 LAUNCHER, M60-SERIES TANK CHASIS, TRANSPORTING,
 AND BRIDGE, 63-FOOT, SCISSORING, CLASS 60

Headquarters, Department of the Army, Washington, D.C
 24 December 1968

Purpose and scope	1	1
Description	2	1
Modes of transportation	3	1
Sectionalization	4	7
Item characteristic and related data	5	7
Appendix		10

1. Purpose and Scope

a. This manual provides transportability guidance for movement of the launcher, M60-series tank chassis (fig. 1), and the bridge, 63-foot, scissoring, class 60. It covers significant transportability and safety considerations in the movement of the launcher and bridge by the various modes of transport. Included are side- and elevation drawings of the launcher (fig. 2 and 3), the 63-foot bridge in scissored position (fig. 4), and characteristic of the launcher and bridge.

b. The reporting of errors, omissions, and recommendations for improving this manual by the individual user is encouraged. Reports should be submitted on DA Form 2028 (Recommended Changes to DA Publications) and forwarded to director, U.S. Army transportation engineering Agency, Military Traffic Management and Terminal Service, ATTN: MTT-GD, Fort Eustis Va. 23604

2. Description

The launcher, M60-series is used for transporting, launching, and retrieving the 63-foot scissoring bridges. It is the M60-series combat-tank chassis modified to accept the bridge-launcher mechanism. The launcher is not shipped with the bridge attached, except for distance from

the assembly area to the launch site or from the retrieving site to the disassembly area. This manual pertains to the transport of the launcher and bridge as separate items.

3. Modes of Transport

a. Shipment by Air.

(1) The launcher, with or without the bridge, cannot be transported by U.S. Army aircraft.

(2) The launcher without a bridge can be transported by the U.S. Air force C-5A aircraft.

(3) The bridge, 63-foot scissored, not crated, cannot be transported by U.S. Army aircraft

(4) The bridge, 63-foot, scissored, not crated, can be transported in the U.S. Air Force C-5A aircraft.

(5) Based on a typical mission of 2,500 nautical miles (4030 km), one way, the bridge when sectionalized, crated or uncrated, is within the dimensional and weight capability of the C-130E, the C-133 series, and the C-141 U.S. Air Force aircraft.

(6) Based on a typical mission of 1,000 nautical miles (1352 km), one way, individual elements of the bridge when sectionalized, crated or uncrated, are within the dimensional and

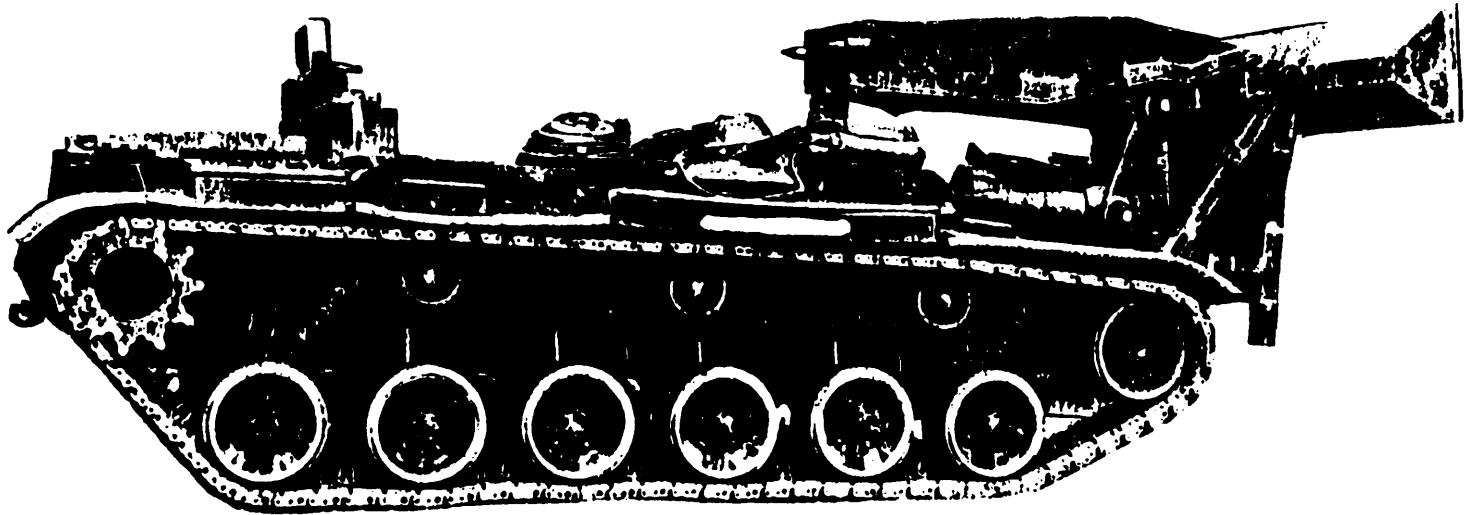

Figure 1. Launcher, M60-series tank chassis, transporting.

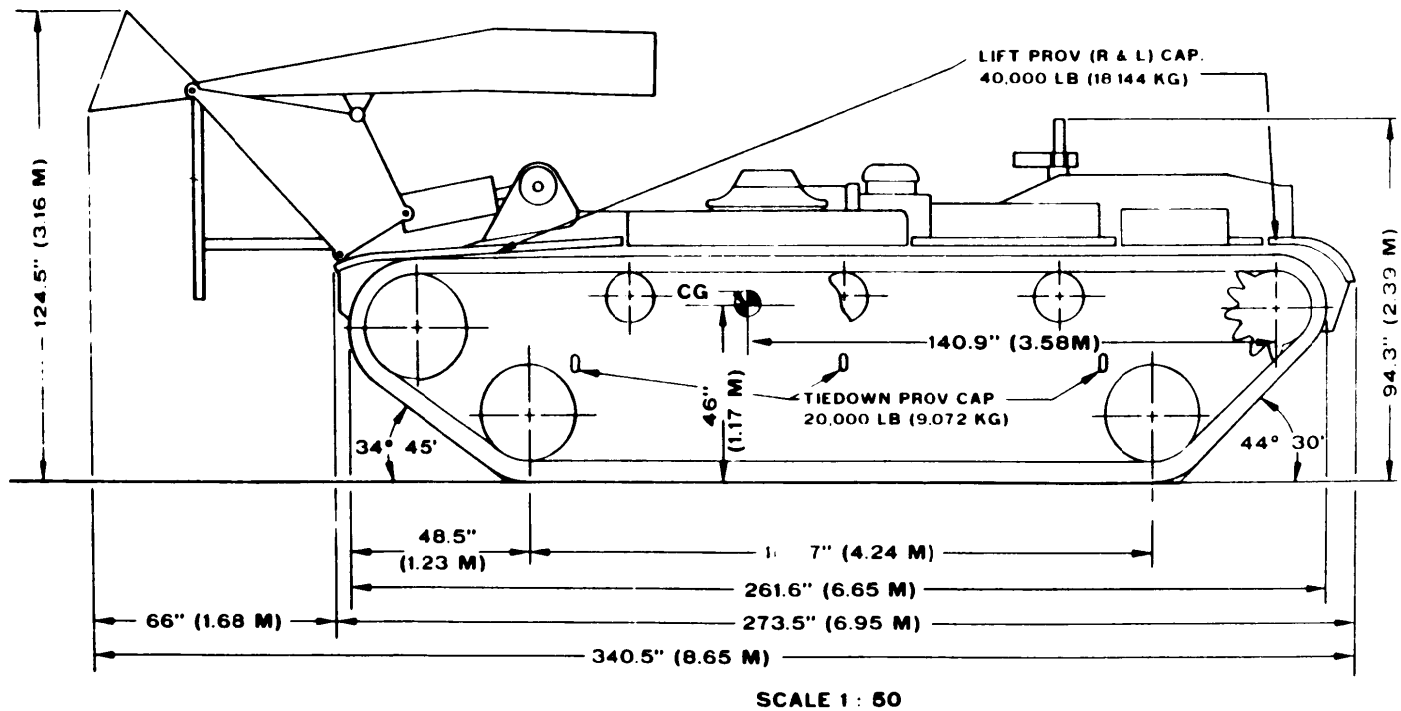

Figure 2. Side elevation (launcher).

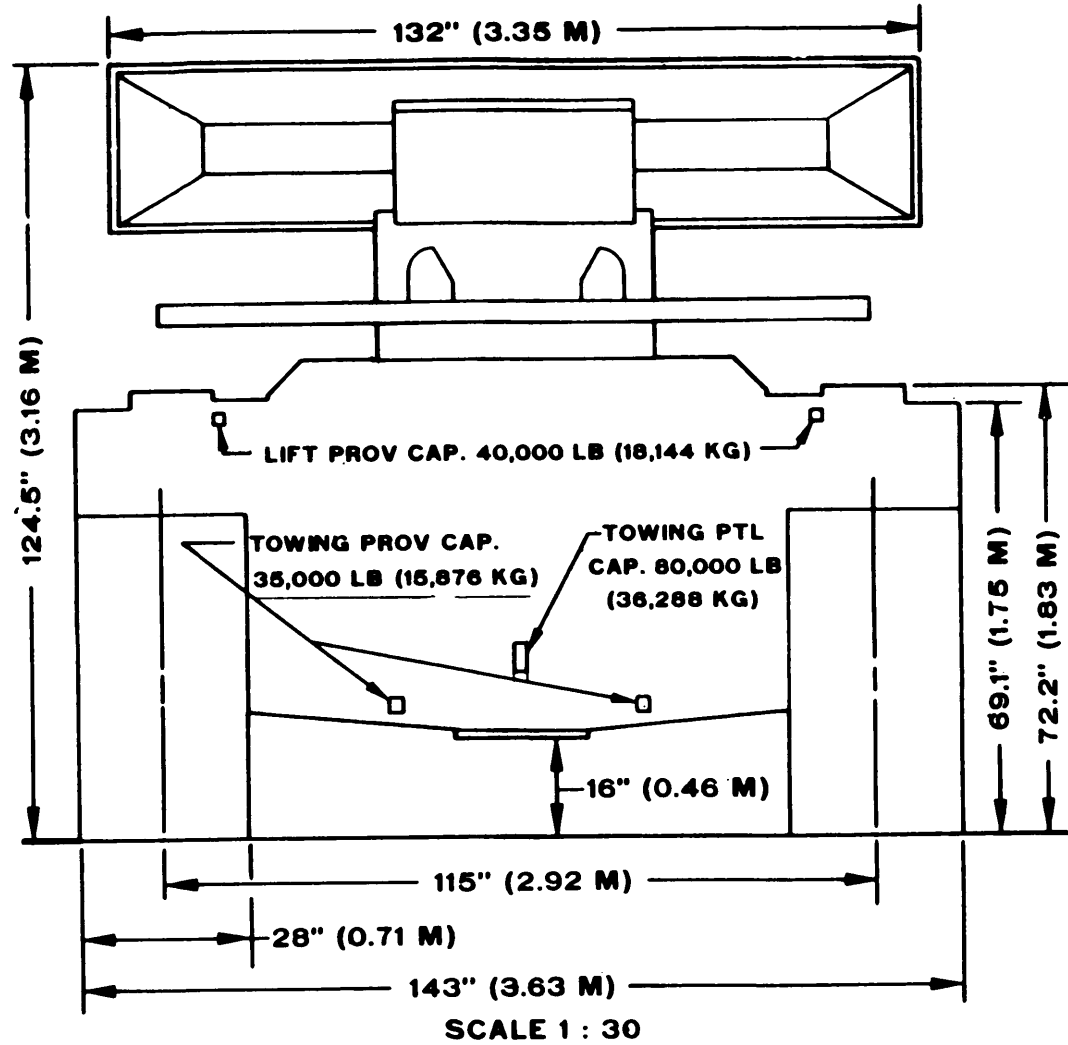

Figure 3. End elevation (launcher).

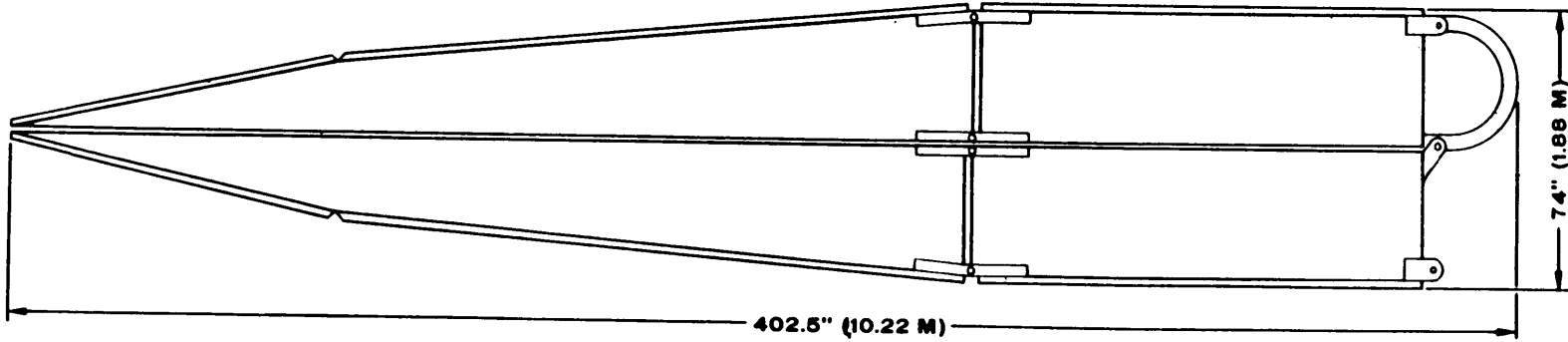

Figure 4. Bridge, 63-foot, scissoring.

weight capability of the C-119, the C-123, and the C-124-, and C-130-series U.S. Air Force aircraft.

Note. The maximum U.S. Air Force aircraft cargo weight and range capabilities are based on the following conditions:

- Standard day conditions
- Sea level operating conditions
- Hard-surfaced runways
- No weather alternate required
- No wind conditions
- Fuel reserve
- Constant cruising altitude

In the event one or more of these operating conditions are changed, the maximum cargo load and/or range may be affected.

b. Shipment by Highway.

(1) *On road.*

(a) *Launcher.* The launcher can be moved over highways under its own power for short distances. It can be transported on the semi-trailer, tank transporter, 50-ton, 8-wheel, M15A2, in combination with the truck, tractor, 10-ton, M123. The item can also be transported by commercial semitrailers of adequate capacity. Moving under its own power or loaded on a semi-trailer, the item exceeds the legal weight and dimensional limits of all of the states and the physical limitations of many highways in CONUS and will require special permits, and at times special routing for movement. It also exceeds the recommended weight and dimensional limits for highway movement in oversea areas, and special routing may be required. Movement over public highways in CONUS should be made only when other modes of transport cannot be utilized.

(b) *Bridge.* The bridge in its sectionalized configuration is normally transported over the highway loaded in the truck, stake, 5-ton (bridge transporting). See TM 5-2510 -200-10-1 for information regarding this truck. Two trucks are required to transport one bridge and its accessories. (See para 5 for dimensions of sectionalized component) The bridge in its assembled configuration (scissored) can also be transported by military and commercial semitrailers of adequate capacity. See TM 5-216 for movement of the scissored bridge by lowbed trailer. In this configuration, the legal width limitation is exceeded in CONUS and special permits will be

required. The recommended width limitation is also exceeded overseas, and special routing may be required.

(2) *Off road: soils trafficability data* The *vehicle cone index (VCI)* is a number which tests have proven can be related to the characteristics of a particular vehicle (see para 5). This number, when used in connection with the rating cone index (of the soil), can forecast the ability of that vehicle to repeatedly cross fine-rained soil, and sands with fines, poorly drained. The rating cone index is obtained by use of the cone penetrometer and its associated equipment. See TB ENG 37 for use of the equipment in the field and for interpretation of index numbers.

c. Shipment by Rail.

(1) *Launcher.* Loaded on a railroad flat-car, the launcher can be transported but it exceeds the width limitations of the "Outline Diagram for Single Loads, Without End Overhang, on Open Top Cars"* for shipments within CONUS, and verification of line clearances will be required. In countries complying with the Berne International Rail Interchange Agreement, the launcher can be transported by rail but it also exceeds the width and height limitations, and verification of line clearances will be required. See appendix for information regarding blocking and restraining the launcher on railroad flatcars.

(2) *Bridge.* The bridge is shipped by rail in the sectionalized configuration and presents no transportability problems.

d. Shipment by Water.

1) *Launcher.* The launcher can be transported by inland waterway cargo carriers and lighters of adequate capacity. It can also be shipped by Mariner-, Victory-, and Liberty-class seagoing vessels, subject to the following limitations:

<i>Class</i>	<i>Hatch size adequate</i>	<i>Hatch boom adequate</i>	<i>Hatches requiring terminal crane</i>
Mariner	No. 2, 3, 4, 5, 6, 7	No. 4, 6.	No. 2, 3, 5, 7
Victory.	No. 3, 4,	No. 3	No. 4
Liberty . .	No. 1, 2, 4, 5.	No. 2**.	No. 1, 4, 5

(2) *bridge.* The sectionalized bridge can be Shipped without limitations.

*Detailed information available in railway Line Clearance publication.
 **When hatch is equipped with 50-ton boom.

4. Sectionalization

a. *Launcher.* Sectionalization of the launcher is not required. It is shipped with the launching mechanism in travel configuration. This configuration will provide the minimum dimensional length, 340.5 inches (8.65 m), and the maximum dimensional height, 124.5 inches (3.16 m).

b. *Bridge.* The bridge must be completely sectionalized for unrestricted transport, by all

modes. The bridge breaks down into nine major components, consisting of four center sections, four ramp sections, and one group of accessories. When so grouped, packed, and crated, the shipment will weigh approximately 30,880 pounds (14007 kg) and will require approximately 2,548.7 cubic feet (72.13 cu m). Authorized personnel, special equipment, and handtools are required for this sectionalization. See TM 5-216 for detailed instructions.

5. Item Characteristics and Related Data

Nomenclature — Launcher, M60 Series Tank Chassis, Transporting, and Bridge, 63-foot, Scissoring, Chass 60

FAN5420-88%2020
 LIN(SB 700-20)..... L43664
 Type Classificationstandard A

Nomenclature — Bridge, Armored- Vehicle-Launched, Scissoring-Type, Class 60; Aluminum, 63-Foot Span

FSN5420-522-9599
 LIN(SB 700-20) C20414
 Type Classification.Standard A

Launcher Without Bridge

Item Weight.....91,900 lb (41686 kg)
 Center of Gravity:
 Above Ground 46 in. (1.17m)
 From CL Rear Drive Sproket 140.9in. (3.58m)
 Unit Ground Pressure9.8 psi (0.69 kg/sq cm)

Launcher With Bridge

Item Weight122.780 lb (55693 kg)
 Center of Gravity:
 Above Ground56 in. (1.42 m)
 From CL Rear Drive Sprocket.120.3in. (3.06m)
 Unit Ground Pressure.....13.2 psi (0.93 kg. sq cm)

Launcher With Launching Mechanism in Travel Position

Item Dimensions:
 Length340.5 in. (8.65 m)
 Width.143 in. (3.63m)
 Height.124.5in. (3.16m)

Shipping Data:
 Volume3.528.2 cuft (99.28 cum)
 Area338.1 sq ft (31.41 sq m)

Launcher With Launching mechanism in Launch Position

Item Dimensions:
 Length467.1 in. (11.86m)
 Width143 in. (3.63m)
 Height94.3 in. (2.40m)

Shipping Data:
 Volume3.643.4 cuft (103.11 cu m)
 Area463.9 sq ft (43.10 sq m)

Bridge, 63-Foot Scissored, Not Crated

Item Dimensions:
 Length402.5in. (10.21m)
 Width.....158 in. (4.01 m)
 Height74 in. (1.88 m)

Shipping Data:
 Volume..2,723.4 cu ft (77.07 cu m)
 Area441.6 sq ft (41.03 sq m)
 Weight. 30,880lb (14007kg) kg

4 Bridge Center Sections, Crated (1 each crate)

Item Dimensions (each section):

Length129 in. (3.28m)
Width68 in. (1.73m)
Height 40.5 in. (1.03m)

Shipping Data: 1

Volume (each section)205.6 cuft (5.82cu m)
Area (each section)60.9 sq ft (5.66 sq m)
Weight (4 sections)8,0801b(3665 kg)

4 Bridge section

Item Dimensions (each section):

Length129 in. (3.28m)
Width.....67in. (1.70m)
Height36 in. (0.97m)

Shipping Data:

Volume (each section)190.1 cu ft (5.38 cum)
Area (each section)60 sq ft (5.58 sq m)
Weight (4 sections)7,320 lb (3320 kg)

4 Bridge Ramp Sections, Crated (1 each crate)

Item Dimensions (each section):

Length264 in.(6.71m)
Width..68 in. (1.73m)
Height37 in. (0.94m)

Shipping Data:1

Volume (each section).384.4 cu ft(10.88 cu m)
Area (each section)124.7 sqft(11.58 sq m)
Weight (4 sections) 17,2001b (7802 kg)

4 Bridge Ramp Section, Uncrated

Item Dimensions (each section):

Length264 in. (6.71m)
Width67 in. (1.70m)
Height.33 in. (0.84m)

Shipping Data:1

Volume (each section).337 .8 cu ft (9.56 cum)
Area (each section) 122.8 sq ft(11.41eqm)
Weight (seaction)s15,160 lb(6877 kg)

Bridge accessories, crated (1 each)

Item Dimensions:

Length130 in. (3.30m)
Width57 in. (1.45m)
Height. 44 in. (1.12m)

Shipping Data:1

Volume. 188.7 cu ft (5.34 cum)
Area51.5 sq ft(4.78eqm)
Weight5,280 lb (2395 kg)

Launcher, M60 Series, Tank Chassis

Angle of Approach34° 45'
Angle of Departure. 44° 30'
Turning Radii (R&L). Pivot

Launcher Without Bridge

Vehicle Classification 40

Launcher With 63 foot Bridge

Vehicle Classification:

10-foot span bridge70
20-foot span bridge.61
30-foot span bridge.. . . .59
40-foot span bridge.58
W-foot, and greater, span bridge57

Soils Trafficability Data (See para 3b (2)):

- Item 1. Launcher, at curb weight plus personnel —
91,900 lb (41686 kg) VCI 46
- Item 2. Launcher, at curb weight plus personnel —
91,900 lb (41666 kg), transporting 63-foot
bridge weighting 30,660 lb (14007 kg) VCI 61

Launcher

- CONUS Freight Classification. Machinery noibn
- Uniform Freight Classification (UFC) Item 63220
- CONUS Freight Classification. Machinery noi
- National Motor Freight Classification (NMFC) Item 133300

Bridge

- CONUS Freight Classification. Aluminum structural forms, noibn, fabricated from bans,
plates or shapes 3/16-inch thick or thicker.
- Uniform Freight Classification (UFC) Item 5620
- CONUS Freight Classification. Aluminum structural forms, noi, fabricated from bare,
plates or shapes 3/16-inch thick or thicker.
- National Motor Freight Classification (NMFC). Item 13750
- Publication.. TB ENG 37
- TM 5-216
- TM 5-2510-200-10-1
- TM 5-5420-202-10

¹Data extracted from actual shipping documents; weight and dimensional data may vary according to crafting material used

²Two of the center sections weigh 1,840 lb (835 kg) each, and the other two sections weigh 1,820 lb (826 kg) each.

³Two of the ramp sections weigh 3,800 lb (1724 kg) each, and the other two sections weigh 3,780 lb (1715 kg) each.

APPENDIX

RAIL TRANSPORTABILITY GUIDANCE

Blocking and Restraining Launcher on Railroad Flatcars with Wooden Floors

1. Bill of Material

	Type of material	Quantity
<i>a. Lumber.</i> Douglas-fir or comparable lumber with straight grain free from material defects, fed spec MM-L-751		
2- x 4-in.....		.167 linear ft
2- x 12-in		.60 linear ft
6- x 6 in		.78 linear ft
<i>b. Nails.</i> Common or cement-coated, fed spec FF-N-105		
20d		.250
30d		.108
<i>c. Wire Rope.</i> 5/8-in., 6x19, IWRC, improved plow steel, preformed, regular-lay, fed spec RR-W-410a.200ft		
<i>d. Clamps.</i> Wire-rope, saddled, single grip, steel, milstd 16842.		.20
<i>e. Thimbles.</i> Std. 3/8-in., open-type.		.4

2. Application of Materials (fig. 5 and 6)

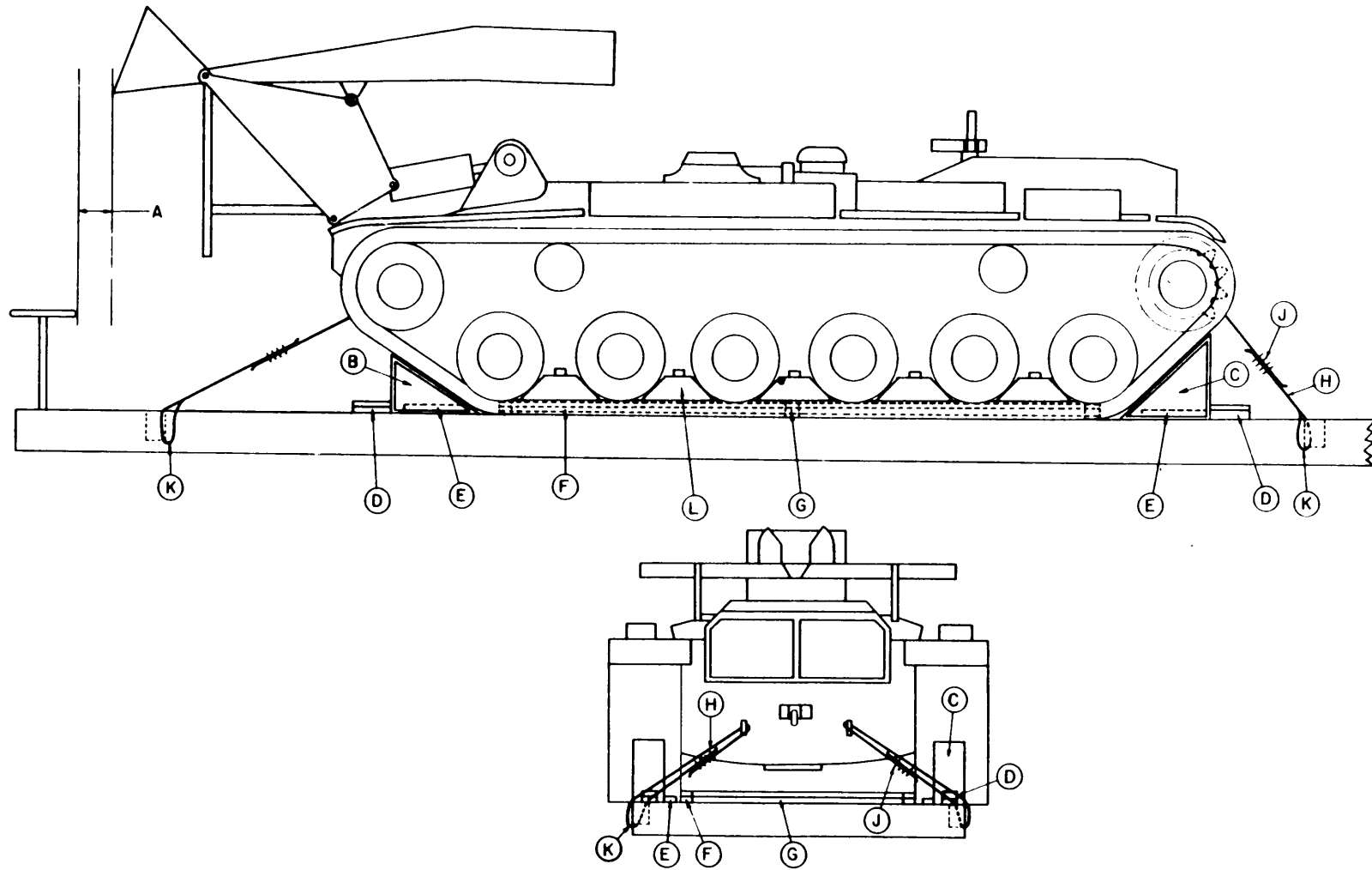
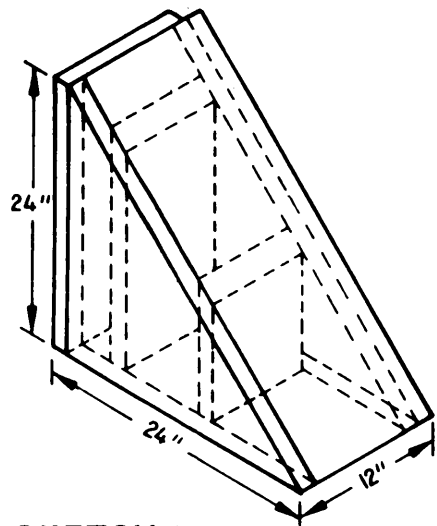
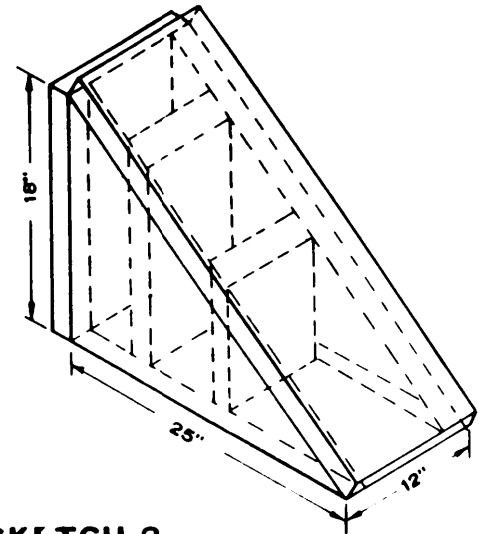

Figure 5. Blocking and restraining diagram.



SKETCH 1



SKETCH 2

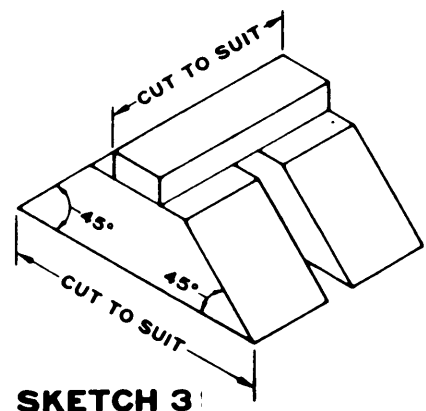

SKETCH 3

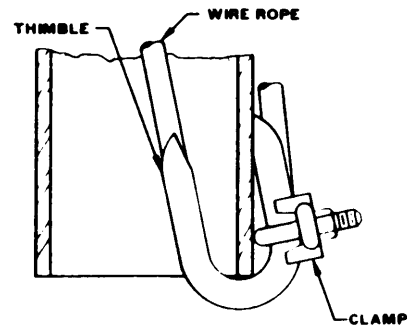

SKETCH 4

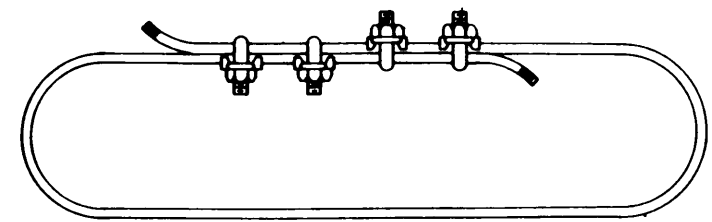

SKETCH 5

Figure 6. Blocking and restraining detail diagram.

<i>Item</i>	<i>No. required</i>	<i>Application</i>	<i>Item</i>	<i>No. required</i>	<i>Application</i>
A	—	Brake wheel clearance. Minimum clearance required is 6 in. above, in back of, and on both sides of and 4 in. underneath wheel.			center and one near each end of item F. Secure the lower piece to the car floor with 30d nails spaced 8 inches apart and the top piece to the one below in like manner.
B	2	Front track block (sketch 2, fig. 6). Locate angle end under track. Secure with 20d nails.	H	4	Wire rope, ½-in., 6x19, IWRC. Each one to make a complete loop with the overlapped ends secured with four ½-in. wire-rope clamps. Attach one wire rope to each towing eye located at each end of the vehicle and to a stake pocket on the same side of the car.
C	2	Rear track block (sketch 1, fig. 6). Locate angle end under track. Secure with 20d nails.	(2 each end)		
D	8	2- x 4- x 12-in. cleat for items B and C. Each cleat to consist of two pieces. Locate in front of the front blocks and behind the rear blocks. Secure the lower piece of each cleat to the car floor with four 20d nails. Fasten the top piece to the lower in like manner.	J	20	Wire-rope clamps. Secure each wire rope with four clamps. Secure each thimble, item L, to wire rope with one clamp at the stake pocket.
E	8	2- x 4- x 20-in. cleat for items B and C. Locate one piece longitudinally along the inside of each item B and C, and secure to the car floor with four 20d nails.	K	4	Thimbles. Secure one thimble to each wire rope at the bottom of the stake pocket. See figure 6, sketch 4.
F	2	Each to consist of two pieces of 2- x 4-in. x 14-ft lumber. Locate on floor against the inside of each crawler tread. Secure lower piece to the car floor with twelve 30d nails and the top piece to the one below in like manner.		10	Each to consist of two pieces of 6- x 6-in. x length-to-suit, cut to fit contour of bogie wheels. Locate one piece between the inside and outside wheels of each bogie assembly. Locate one piece of 2- x 4-in. x length-to-suit, across top of each bogie block as shown on sketch 3, figure 6, and nail to each block with two 20d nails.
G	3	Each to consist of two pieces of 2 x 4-in. x length cut to fit between item F. Locate one near the			

4. General Notes

- a. Load as shown is based on a railroad flatcar 10 feet 5 inches wide (platform). Every effort should be made to obtain a car as wide as possible.
- b. Apply handbrakes, place transmission gears in neutral position, and wire or block the levers in place.
- c. Thimbles must be used between tiedown wire rope and bottom of stake pockets. Each thimble will be secured to the tiedown with one wire-rope clamp.
- d. Tensioning of wire-rope loops can be accomplished by using a suitable come-along-type mechanical hoist or turnbuckles. When turnbuckles are used to tension wire rope, they must be wired or locked to prevent them from turning.
- e. Ends of ½-inch-diameter wire rope must overlap a minimum of 18 inches. Spacing between ½-inch wire-rope clamps must be 3¼ inches with a minimum distance of 3 inches from each dead end of the wire rope to the first wire-rope clamp. Wire-rope clamps must be applied with the "U"-bolt against the dead end line of the wire rope and the base of the clamp against the loadline of the wire rope. (See Ordnance Corps Drawing 19-48-C-ORDJU-588, entitled, "Wire Rope and Annealed Wire Application Methods for Securing Lading or Rail and Motor Carrier Equipment".)
- f. For further details, refer to Association of American Railroads (AAR) "Rules Governing the Loading of Commodities on Open Top Cars", and General Rules 3. 4. 5. 7. 9, 14, 15, and 19A therein.

By Order of the Secretary of the Army:

W. C. WESTMORELAND,
General, *United States Army*,
Chief of Staff.

Official:

KENNETH G. WICKHAM,
Major General, United States Army,
The Adjutant General.

Distribution: To be distributed in accordance with DA Form 12-25 Sec I (qty rqr Block #57), Operator requirements for Bridges Launcher (AVL).

☆ U.S GOVERNMENT PRINTING OFFICE : 1992 O - 311-831 (61343)

RECOMMENDED CHANGES TO EQUIPMENT TECHNICAL PUBLICATIONS



THEN...JOT DOWN THE
DOPE ABOUT IT ON THIS FORM.
CAREFULLY TEAR IT OUT, FOLD IT
AND DROP IT IN THE MAIL.

SOMETHING WRONG WITH PUBLICATION

FROM: (PRINT YOUR UNIT'S COMPLETE ADDRESS)

DATE SENT

PUBLICATION NUMBER

PUBLICATION DATE

PUBLICATION TITLE

BE EXACT PIN-POINT WHERE IT IS

PAGE
NO.

PARA-
GRAPH

FIGURE
NO.

TABLE
NO.

IN THIS SPACE, TELL WHAT IS WRONG
AND WHAT SHOULD BE DONE ABOUT IT.

TEAR ALONG PERFORATED LINE

PRINTED NAME, GRADE OR TITLE AND TELEPHONE NUMBER

SIGN HERE

THE METRIC SYSTEM AND EQUIVALENTS

WEIGHT MEASURE

1 Centimeter = 10 Millimeters = 0.01 Meters = 0.3937 Inches
 1 Meter = 100 Centimeters = 1000 Millimeters = 39.37 Inches
 1 Kilometer = 1000 Meters = 0.621 Miles

WEIGHTS

1 Gram = 0.001 Kilograms = 1000 Milligrams = 0.035 Ounces
 1 Kilogram = 1000 Grams = 2.2 lb.
 1 Metric Ton = 1000 Kilograms = 1 Megagram = 1.1 Short Tons

LIQUID MEASURE

1 Milliliter = 0.001 Liters = 0.0338 Fluid Ounces
 1 Liter = 1000 Milliliters = 33.82 Fluid Ounces

SQUARE MEASURE

1 Sq. Centimeter = 100 Sq. Millimeters = 0.155 Sq. Inches
 1 Sq. Meter = 10,000 Sq. Centimeters = 10.76 Sq. Feet
 1 Sq. Kilometer = 1,000,000 Sq. Meters = 0.386 Sq. Miles

CUBIC MEASURE

1 Cu. Centimeter = 1000 Cu. Millimeters = 0.06 Cu. Inches
 1 Cu. Meter = 1,000,000 Cu. Centimeters = 35.31 Cu. Feet

TEMPERATURE

$5/9(^{\circ}\text{F} - 32) = ^{\circ}\text{C}$
 212° Fahrenheit is equivalent to 100° Celsius
 90° Fahrenheit is equivalent to 32.2° Celsius
 32° Fahrenheit is equivalent to 0° Celsius
 $9/5^{\circ}\text{C} + 32 = ^{\circ}\text{F}$

APPROXIMATE CONVERSION FACTORS

TO CHANGE	TO	MULTIPLY BY
Inches	Centimeters	2.540
Feet	Meters	0.305
Yards	Meters	0.914
Miles	Kilometers	1.609
Square Inches	Square Centimeters	6.451
Square Feet	Square Meters	0.093
Square Yards	Square Meters	0.836
Square Miles	Square Kilometers	2.590
Acres	Square Hectometers	0.405
Cubic Feet	Cubic Meters	0.028
Cubic Yards	Cubic Meters	0.765
Fluid Ounces	Milliliters	29.573
its	Liters	0.473
arts	Liters	0.946
allons	Liters	3.785
Ounces	Grams	28.349
Pounds	Kilograms	0.454
Short Tons	Metric Tons	0.907
Pound-Feet	Newton-Meters	1.356
Pounds per Square Inch	Kilopascals	6.895
Miles per Gallon	Kilometers per Liter	0.425
Miles per Hour	Kilometers per Hour	1.609

TO CHANGE	TO	MULTIPLY BY
Centimeters	Inches	0.394
Meters	Feet	3.280
Meters	Yards	1.094
Kilometers	Miles	0.621
Square Centimeters	Square Inches	0.155
Square Meters	Square Feet	10.764
Square Meters	Square Yards	1.196
Square Kilometers	Square Miles	0.386
Square Hectometers	Acres	2.471
Cubic Meters	Cubic Feet	35.315
Cubic Meters	Cubic Yards	1.308
Milliliters	Fluid Ounces	0.034
Liters	Pints	2.113
Liters	Quarts	1.057
ers	Gallons	0.264
ms	Ounces	0.035
ograms	Pounds	2.205
Metric Tons	Short Tons	1.102
Newton-Meters	Pounds-Feet	0.738
Kilopascals	Pounds per Square Inch	0.145
ometers per Liter	Miles per Gallon	2.354
ometers per Hour	Miles per Hour	0.621



PIN: 009637-000